



中国《专利法》第四次修改中
关于外观设计条款的修订
以及中国关于图形用户界面的审查

**Design Patents and Examination of GUIs in the 4th
Amendment to the Patent Law**



中国《专利法》第四次修改中关于外观设计条款的修订

Design Patents in the 4th Amendment to the Patent Law



内容 Contents



国家知识产权局
China National Intellectual Property
Administration

- **延长外观设计专利保护期限**
Longer term of protection
- **增加局部外观设计制度**
Partial design: a new addition
- **增加外观设计本国优先权制度**
Domestic priority: a new addition
- **完善专利权评价报告制度**
Better evaluation report



01

延长外观设计专利保护期限 Longer term of protection



【专利法第四十二条】 Patent Law: Article 42

发明专利权的期限为二十年，实用新型专利权的期限为十年，外观设计专利权的期限为十五年，均自申请日起计算。

The term of a patent for an invention shall be 20 years, the term of a patent for a utility model shall be ten years, and the term of a patent for a design shall be 15 years, all commencing from the date of filing of application.



02

增加局部外观设计制度

Partial design: a new addition



【专利法第二条】 Patent Law: Article 2

外观设计，是指对产品的**整体或者局部**的形状、图案或者其结合以及色彩与形状、图案的结合所作出的富有美感并适于工业应用的新设计。

“Design” means a new design of the shape, pattern, or a combination thereof, as well as a combination of the color, shape and pattern, of **the entirety or a portion** of a product, which creates an aesthetic feeling and is fit for industrial application.

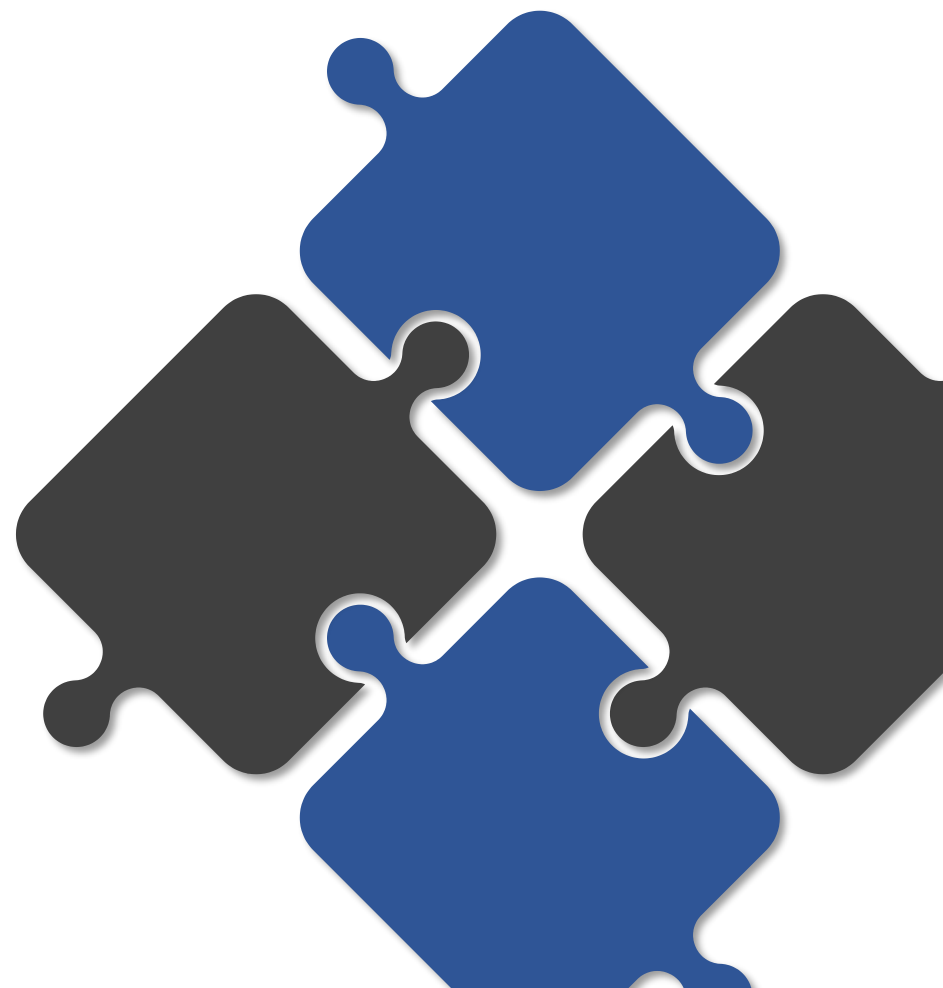

【实施细则第二十七条】（2020年11月27日对外征求意见稿）

Implementation Rules of the Patent Law: Article 27 (Exposure Draft for Comment, November 27, 2020). Hereinafter “Draft Implementation Rules”.

.....

申请局部外观设计专利的，应当提交整体产品的视图，并用虚线与实线相结合或者其他方式表明所需要保护的内容。

The application of a partial design shall contain the view of the whole of a product, where the parts seeking protection are indicated by, inter alia, a combination of dotted and solid lines.

.....

【实施细则第二十八条】（2020年11月27日对外征求意见稿）

Draft Implementation Rules: Article 28

.....

申请局部外观设计专利的，必要时在简要说明中写明请求保护的局部。

The application of a partial design shall designate in the brief explanation the parts seeking protection.

.....

图片或者照片 -- 虚实线结合

Drawings or photos — a combination of dotted and solid lines

- 应当包含整体设计
View of the product as a whole must be provided
- 立体产品应当提交清楚显示局部的立体图
Clear 3D view of the partial design is needed for 3D products
- 实线表示需要保护的局部，虚线表示其他部分
Solid lines for the partial design, dotted lines for the rest of the product

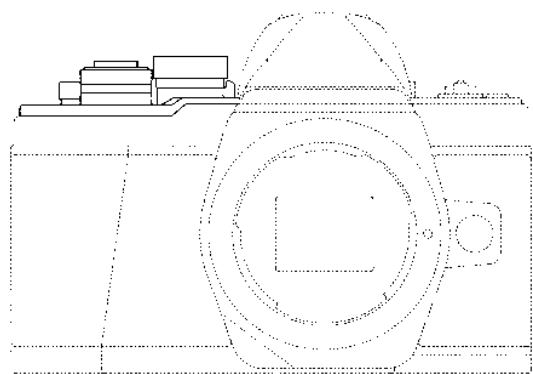

主视图 Front view

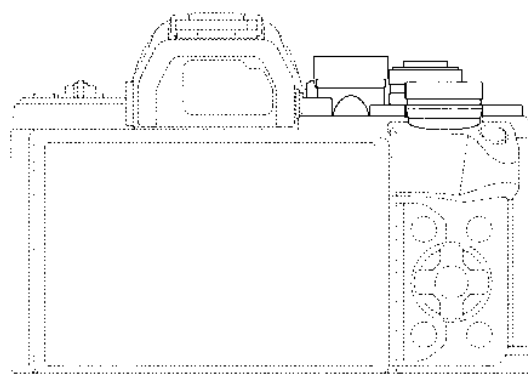

后视图 Back view

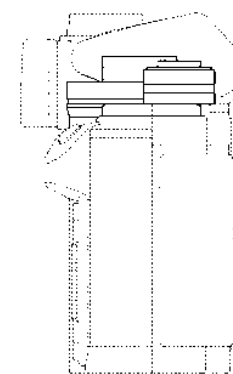

左视图 Left view

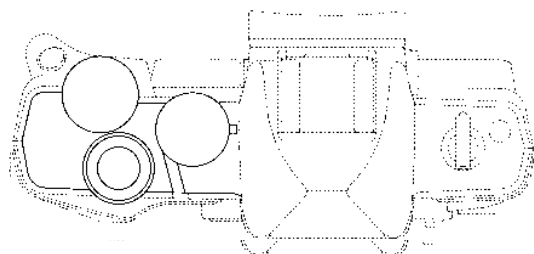

俯视图 Top view

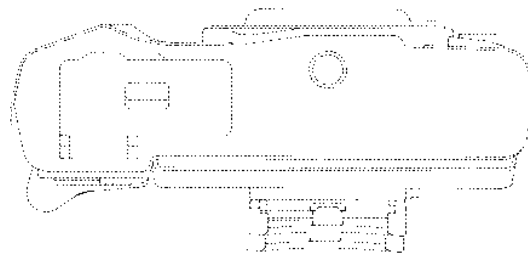

仰视图 Bottom view

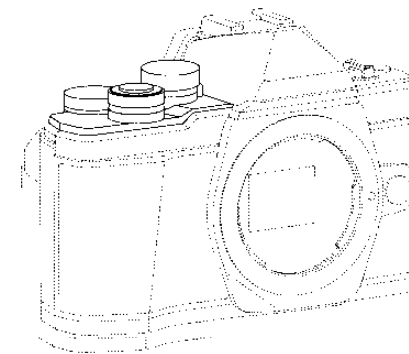

立体图 3D view

图片或者照片 — 点划线
Drawings or photos — dash-dot lines

必要时，应当用点划线表示局部外观设计中要求保护的局部与其他部分之间的分界线

When necessary, use dash-dot lines to indicate the boundary between the partial design and the rest of the product

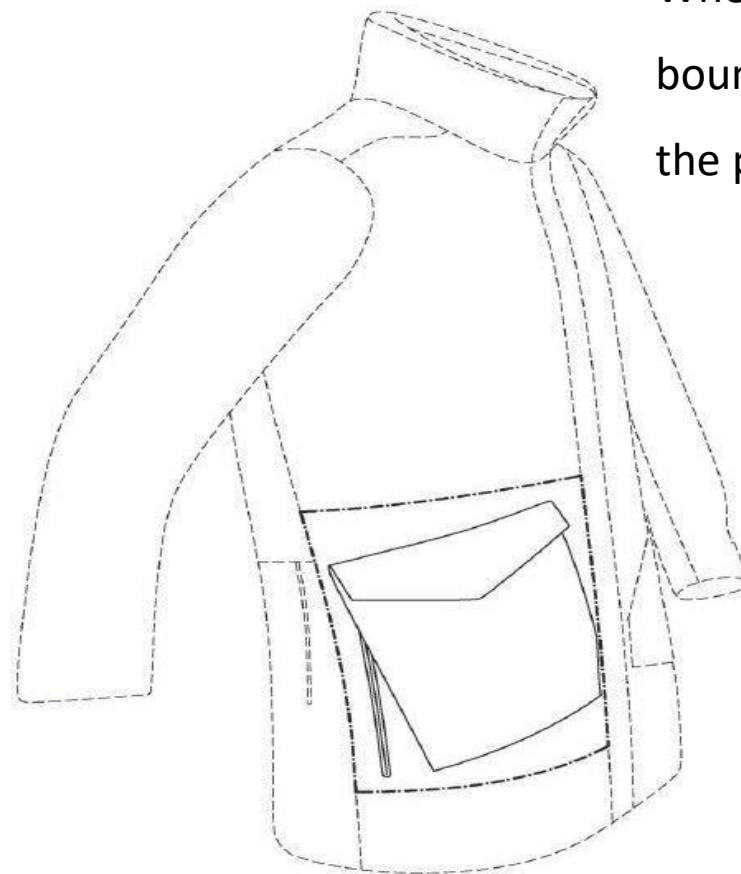

图片或者照片 -- 半透明涂覆
Drawings or photos — translucent overlay

用单一颜色的半透明层覆盖不需要保护的部分
Use a translucent & monochrome overlay to cover the parts other than the partial design



主视图 Front view



后视图 Back view



俯视图 Top view



左视图 Left view



右视图 Right view



立体图1 3D view 1



立体图2 3D view 2



03

增加外观设计 本国优先权制度

Domestic priority: a new addition



【专利法第二十九条】 Patent Law: Article 29

申请人自发明或者实用新型在中国第一次提出专利申请之日起十二个月内，或者自外观设计在中国第一次提出专利申请之日起六个月内，又向国务院专利行政部门就相同主题提出专利申请的，可以享有优先权。

Where, within 12 months from the date of filing of the first application for a patent for an invention or utility model in China, or within six months from the date of filing of the first application for a patent for a design in China, the applicant files again an application for a patent for the same subject matter with the patent administrative department of the State Council, the applicant may enjoy a right of priority.

【实施细则第三十二条】（2020年11月27日对外征求意见稿） Draft Implementation Rules: Article 32

.....

外观设计专利申请的申请人要求本国优先权，在先申请是发明或者实用新型专利申请的，可以就附图显示的相同主题提出外观设计专利申请；在先申请是外观设计专利申请的，可以就相同主题提出外观设计专利申请。

If an applicant claims a domestic priority and the earlier application is an application for an invention patent or a utility model, an application for a design patent may be filed regarding the same subject matter as indicated by the attached drawings to the earlier application. If the earlier application is an application for a design patent, an application for a design patent may be filed regarding the same subject matter.

.....

申请人要求本国优先权的，其在先申请自后一申请提出之日起即视为撤回，但外观设计专利申请的申请人要求以发明或者实用新型专利申请作为本国优先权基础的除外。

When an applicant claims domestic priority, his earlier application shall be deemed to have been withdrawn on the date on which the later application is filed, except where the later application is for a design patent and the applicant claims a domestic priority based on an earlier application for an invention patent or a utility model.

运用本国优先权的主要情形 Circumstances where domestic priority may apply

- 改进设计
Improved design
- 在先申请：A
Earlier application: A
- 在后申请：A+B
Later application: A+B



在先申请 A
Earlier application A

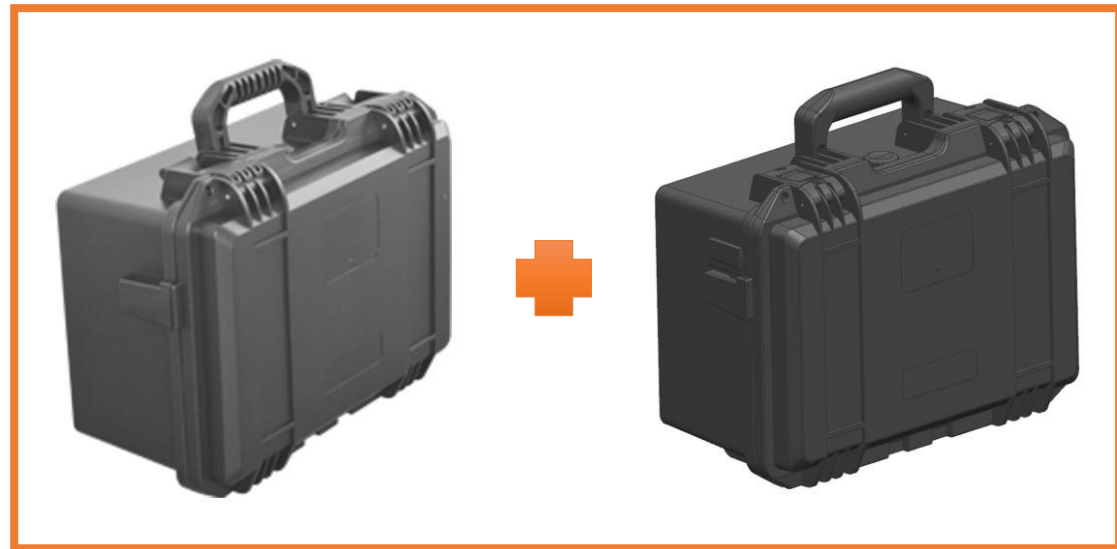

在后申请 A+B
Later application A+B

运用本国优先权的主要情形

Circumstances where domestic priority may apply

- 在先申请实质相同
The earlier application is substantially identical
- 在先申请：单独A和单独B
Earlier applications: A, B (separately)
- 在后申请：A+B
Later application: A+B



在先申请 A
Earlier application A



在先申请 B
Earlier application B

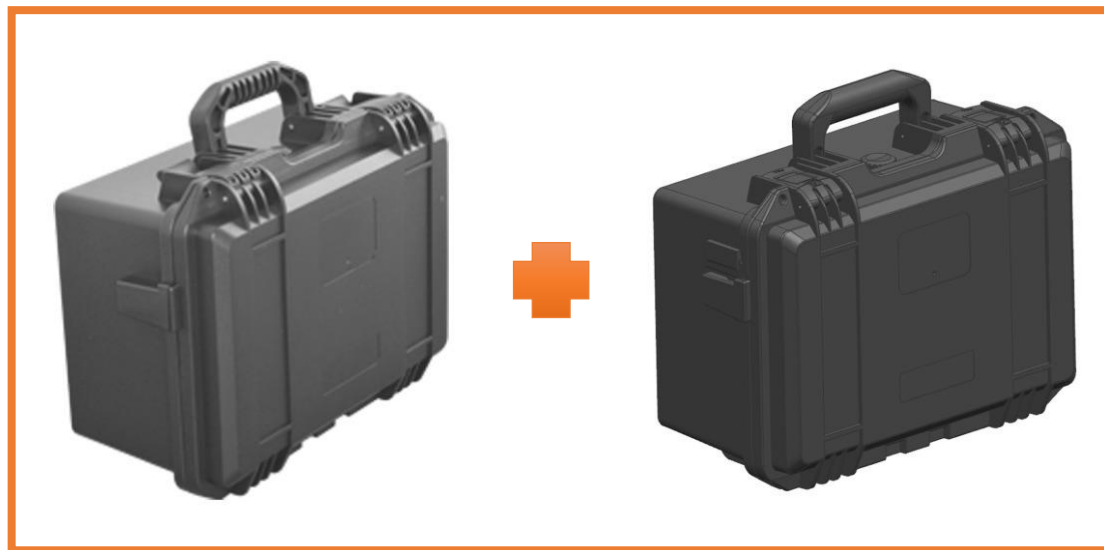

在后申请 A+B
Later application A+B

运用本国优先权的主要情形

Circumstances where domestic priority may apply

- 增加新的套件设计
New design (a suite with the addition of B)
- 在先申请：A
Earlier application: A
- 在后申请：A+B
Later application: A+B



在先申请 A
Earlier application A

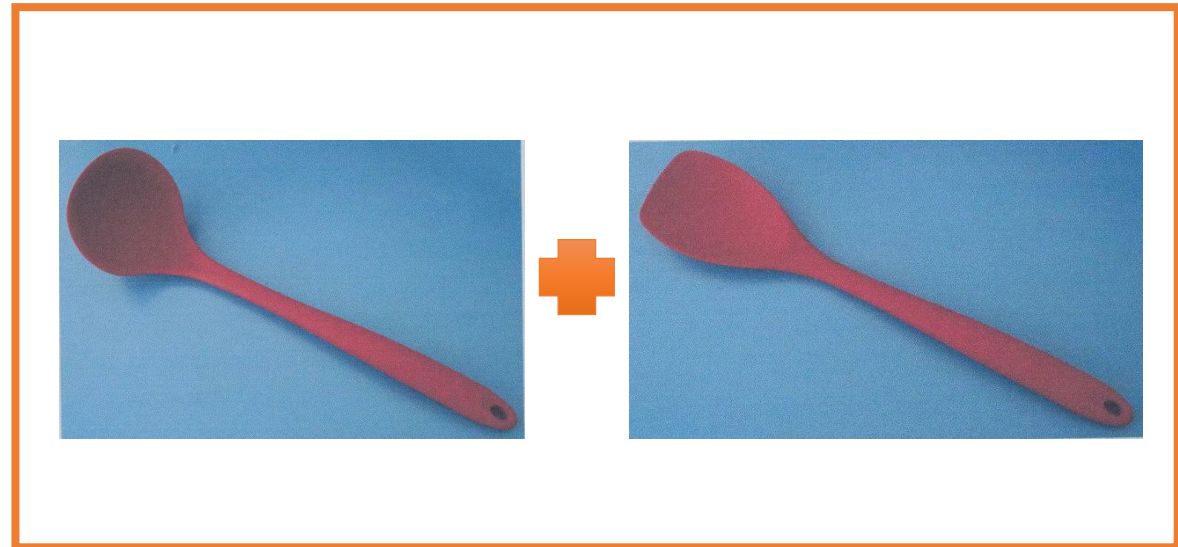

在后申请 A+B
Later application A+B

运用本国优先权的主要情形

Circumstances where domestic priority may apply

- 将套件合案
A suite with the combination of A and B
- 在先申请：单独A和单独B
Earlier applications: A, B (separately)
- 在后申请：A+B
Later application: A+B



在先申请 A
Earlier application A



在先申请 B
Earlier application B

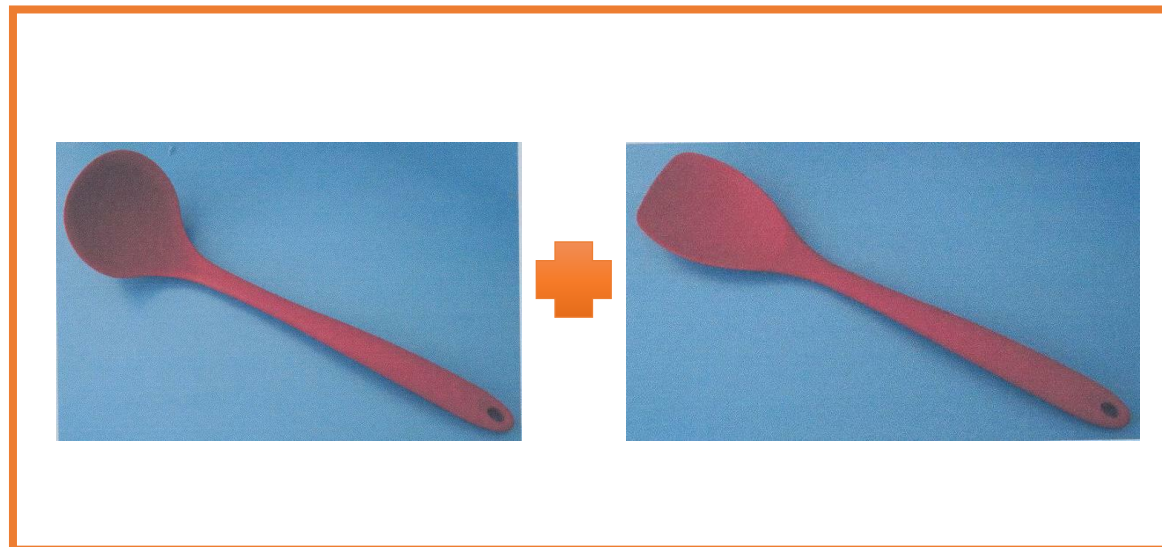

在后申请 A+B
Later application A+B



04

完善专利权评价报告制度

Better evaluation report



【专利法第六十六条第二款】 Patent Law: Article 66.2

.....

专利权人、利害关系人或者被控侵权人也可以主动出具专利权评价报告。

The patentee, the interested party, or the alleged infringer may also voluntarily present the patent evaluation report.



【实施细则第五十六条】（2020年11月27日对外征求意见稿） Draft Implementation Rules: Article 56

授予实用新型或者外观设计专利权的决定公告后，任何单位或者个人可以请求国务院专利行政部门作出专利权评价报告。申请人也可以在办理专利权登记手续时请求国务院专利行政部门作出专利权评价报告。

.....

After a decision on the granting of patent for utility model or design is announced, any entity or individual may request the patent administrative department under the State Council prepare a patent evaluation report. During the patent registration process, an applicant may also request the patent administrative department under the State Council prepare a patent evaluation report.



【实施细则第五十七条】（2020年11月27日对外征求意见稿）

Draft Implementation Rules: Article 57

国务院专利行政部门应当自收到专利权评价报告请求书后2个月内作出专利权评价报告，**但申请人在办理专利权登记手续时请求作出专利权评价报告的，国务院专利行政部门应当自授权公告之日起2个月内作出专利权评价报告。**

.....

The patent administrative department under the State Council shall prepare a patent evaluation report within two months of receiving a request for the same, **or within two months of announcing the decision to grant a patent right where the applicant requests a patent evaluation report during the patent registration process.**





中国关于图形用户界面的审查 Examination of GUIs in China



内容

Contents



- **概述**
Overview
- **可以获得保护的GUI**
GUIs eligible for protection
- **GUI类外观设计申请的要求**
**Requirements for GUI design
patent application**



01

概述 Overview



2014年5月1日通过修改专利审查指南对GUI进行保护

GUI protection was included in a revision to the Patent Examination Guidelines (May 1, 2014)

以前 Prior

产品通电后显示的图案。例如，电子表表盘显示的图案、手机显示屏上显示的图案、软件界面等。上述情况属于不授予专利权的情形。

For the pattern shown when the product is electrified, for example, a pattern on the electronic watch dial, a pattern on the cell phone screen, and a software interface, *no patent right shall be granted for the application.*

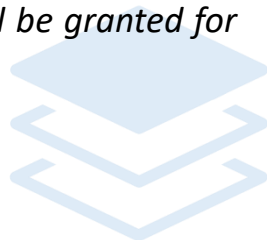

现在 Current

游戏界面以及与人机交互无关的显示装置所显示的图案。例如，电子屏幕壁纸、开关机画面、与人机交互无关的网站网页的图文排版。上述情况属于不授予专利权的情形。

For the pattern displayed in video game interfaces and display devices irrelevant to human-computer interaction (HCI), for example, an electronic screen wallpaper, a startup/shutdown screen, and an image-text layout of a webpage irrelevant to HCI, *no patent right shall be granted for the application.*

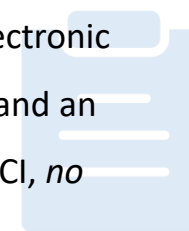



02

可以获得保护的GUI

GUIs eligible for protection



- 只有具有人机交互功能的GUI能够获得保护。 Only GUIs with human-computer interaction (HCI) may be protected.
- 作为整体设计申请的GUI应当附着于其物理载体之上。 The GUI must be attached to its physical medium if the design application is for the product as a whole.



实体按键虚拟化
Virtualization of
physical buttons





带有通话控制系统图
形用户界面的电话

A desk phone with GUI
call control



带有操作系统图形
用户界面的打印机

A printer with GUI
OS (operating
system)



带有播放控制系统图
形用户界面的播放器

A media player with
GUI playback control



带有操作系统图形用
户界面的笔记本电脑

A laptop computer
with GUI OS (operating
system)



带有聊天软件图形用
户界面的台式电脑

A desktop computer
with GUI instant
messaging software



电子屏幕壁纸
Electronic screen wallpaper



开关机界面
Startup/shutdown screen



游戏界面
Video game interface



■ 2021年6月1日，修改后的《专利法》正式实施，设计要点仅在于图形用户界面的外观设计以及可以应用在多种产品上的图形用户界面类外观设计，可以作为局部外观设计提出申请。

Since June 1, 2021, when the newly revised Patent Law came into effect, an application for partial design may be filed if the design essentials only pertain to a GUI design or a design of GUI nature that is applicable to multiple products.

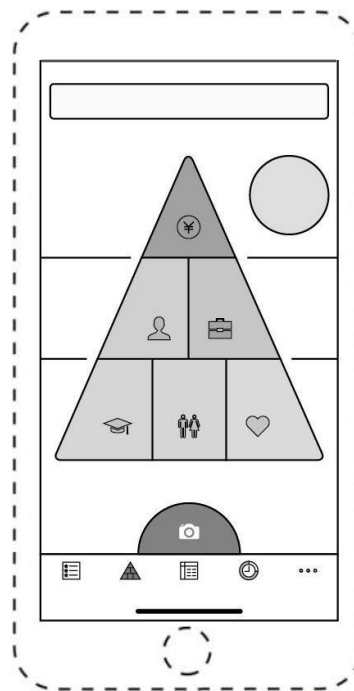
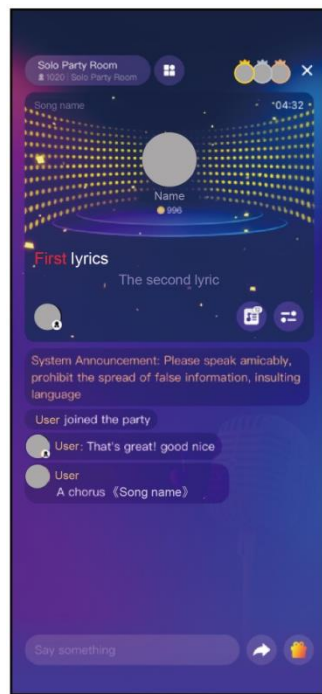



03

GUI类外观设计申请的要求 Requirements for GUI design patent application





应表明图形用户界面的主要用途和其所应用的产品，一般要有“图形用户界面”字样的关键词，动态图形用户界面的产品名称要有“动态”字样的关键词

The principal use(s) and the applied product shall be indicated, along with the keywords “graphic user interface”, and “dynamic” if the GUI is dynamic.



手机的天气预报动态图形用户界面
A smartphone with dynamic GUI for weather service



带有温控图形用户界面的冰箱
A refrigerator with GUI for temperature control



操作图形用户界面
Graphic user operating interface



打印机
Printer

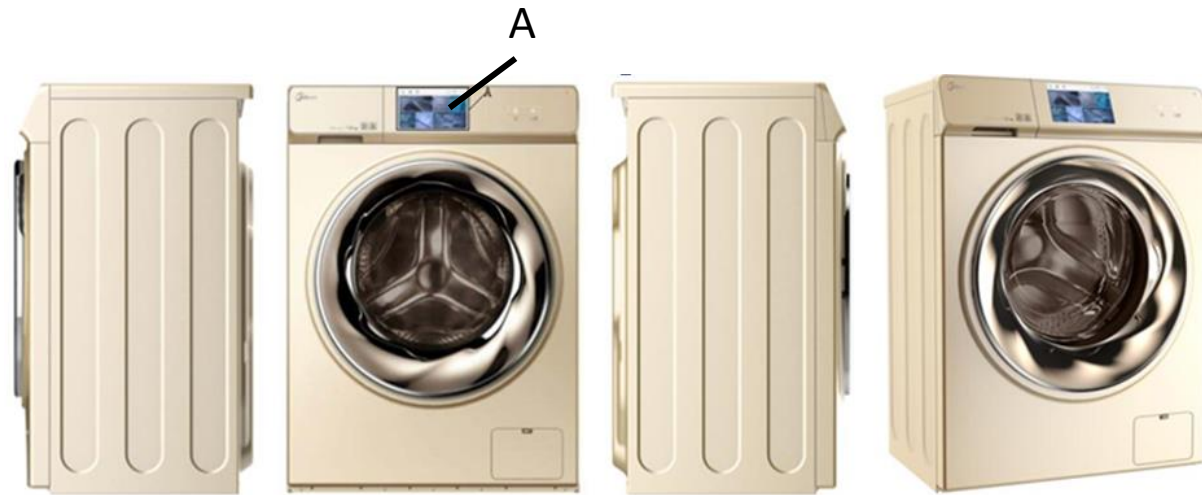

右视图

Right view

主视图

Front view

左视图

Left view

立体图

3D view



界面主视图

GUI front view

带有操作系统图形用户界面的洗衣机

A washing machine with GUI OS

■ 对于用于操作投影设备的图形用户界面，除提交图形用户界面的视图之外，还应当提交至少一幅清楚显示投影设备的视图。

For an application regarding the operating GUI of a projector, a clear view of the projector device must be submitted, along with a view of the GUI.



主视图
Device front view



界面主视图
GUI front view

带有操作系统图形用户界面的投影仪

A project with GUI OS

内容画面 Content view

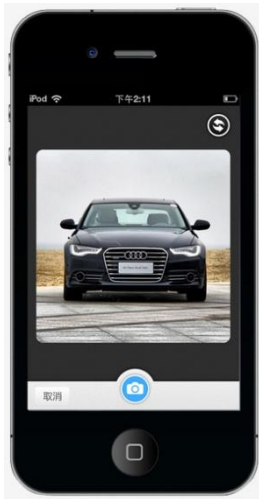

主视图
Front view



主视图
Front view



主视图
Front view

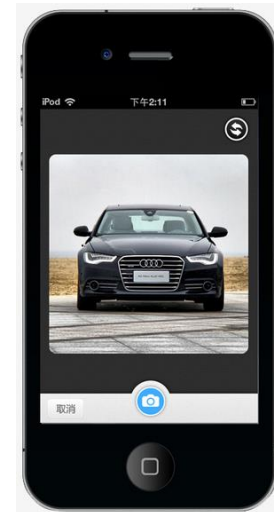

参考图
Reference image

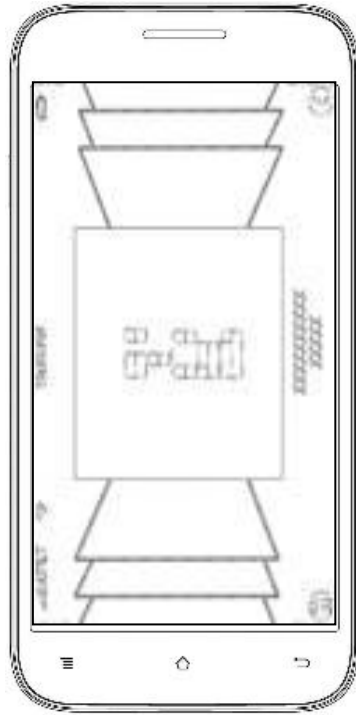

主视图
Front view

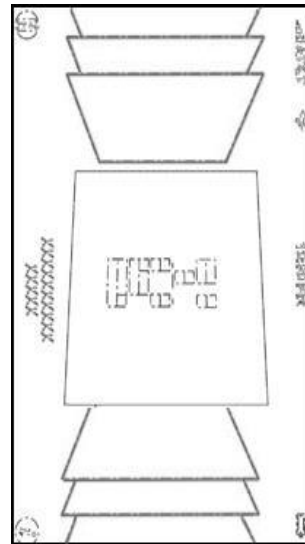

变化状态图1
Dynamic state 1

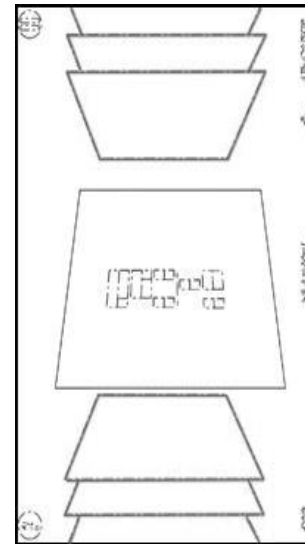

变化状态图2
Dynamic state 2

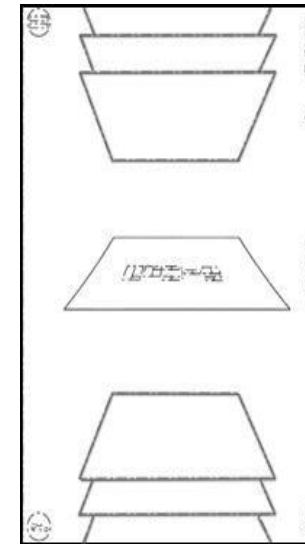

变化状态图3
Dynamic state 3

手机的通讯录动态图形用户界面

Dynamic GUI of the contacts feature on a smartphone

■ 必要时，应当在简要说明中写明图形用户界面的用途，图形用户界面在产品中的区域，人机交互的方式以及变化过程等。

Where necessary, the use(s), position, HCI and dynamic states of the GUI may be indicated in the brief explanation.



图案? 图形用户界面? Icon or GUI?

简要说明:

Brief explanation:

“.....音响表面的麦克风图案是图形用户界面，点击该图案开启录制功能。”

“The microphone icon on the surface of the speaker is a GUI. A user may start recording by tapping the icon.”



国家知识产权局
China National Intellectual Property
Administration



谢谢！
Thank you!